

# RESET-SILENCE SWITCH BOXES



## Key Features

- Stainless steel 22 mm momentary pushbutton switch
- LED ring backlit for high visibility (GG-6 only)
- IP66/NEMA 4 weatherproof design for outdoors or washdown environments
- 24 VDC / 120 VAC rated
- 1.5 Amp normally open contacts
- Circuit board with terminal block for wire landings
- Mounting flanges for wall mounting
- Solution for Compressor Room ventilation remote reset application
- Silence switch allows operators to silence horns if desired
- 2-year warranty

High-visibility remote Reset and Silence switches for gas detection systems.

The S1, R1, and SR1 switches allow the GG-6 and M255 control panels to be located outside of the compressor room with the Reset and Silence switches located inside the compressor room for easy access. A Silence switch can also be located outside of the compressor room.

The switches are connected to the GG-6 or M255, via wire terminals on the switchbox circuit boards. These switches can be used in other controller applications such as PLCs and interlock panels.

The switches are housed in a durable polycarbonate enclosure able to withstand weather and washdown environments for indoor or outdoor mounting applications. A terminal block for wire landings, and mounting flanges are also included for easy installation.

## SPECIFICATIONS

Due to ongoing research and product improvement, specifications are subject to change

**ENCLOSURE:** Polycarbonate, IP66/NEMA 4

**OPERATING TEMPERATURE:** -40°F to +150°F

**MOUNTING PLATE:** Anodized aluminum

**CONTACTS:** (2) NO

**ACTUATOR:** Momentary

**MECHANICAL DURABILITY:** 300,000 cycles

**ILLUMINATION:** LED ring, white

**CURRENT RATING:** 1.5A

**DIMENSIONS:** 6.35" high x 4.42" wide x 3.2" deep

## Configurations

All pushbutton switches are pre-installed and wired in their enclosures

- Order #:** [SB-R1](#) GG-6/M255 Reset pushbutton switchbox, LED, momentary, NEMA 4 enclosure
- [SB-S1](#) GG-6/M255 Silence pushbutton switchbox, LED, momentary, NEMA 4 enclosure
- [SB-SR1](#) GG-6/M255 Silence and Reset pushbutton switchbox, LED, momentary, NEMA 4 enclosure



**ANSI / IIAR 2-2014:**

**6.13 Ammonia Detection and Alarm**

**6.13.2.3** Detection of ammonia concentrations equal to or exceeding 150 ppm (1/2 IDLH) shall activate visual indicators and an audible alarm and shall activate emergency ventilation, where required, in accordance with Section 6.14.7. Once activated, emergency ventilation shall continue to operate until manually reset by a switch located in the machinery room.

**Wiring Diagram Example**

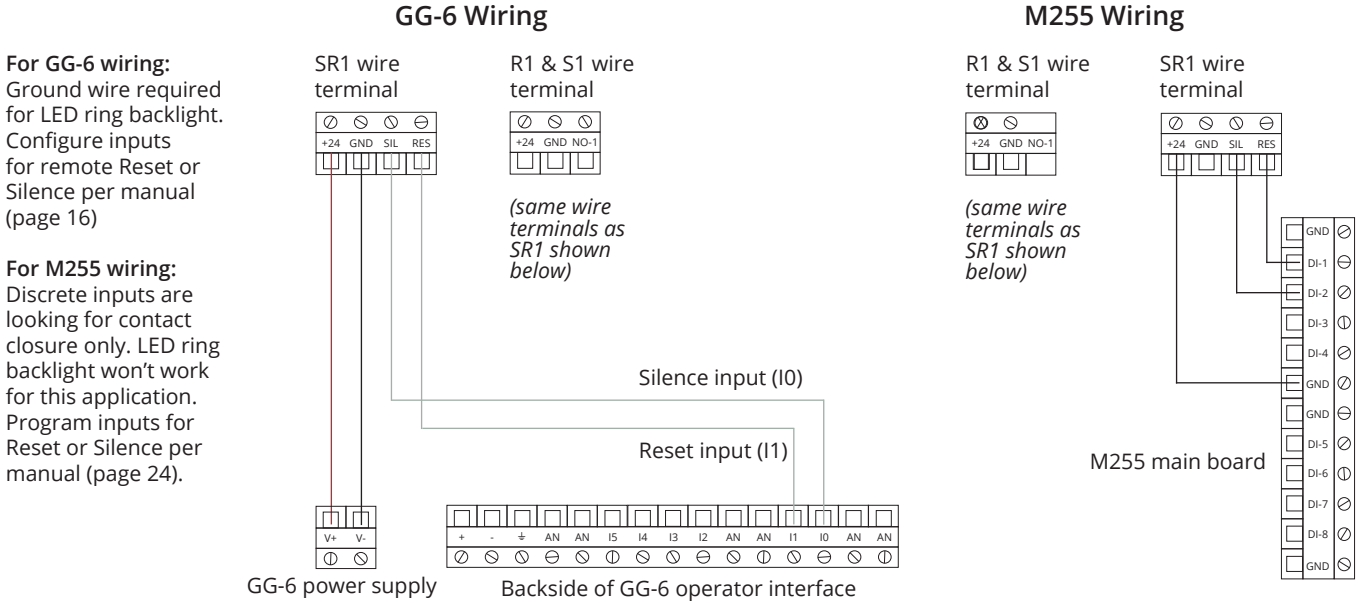

SB-R1 and SB-S1



SB-SR1